

TL081, TL081A, TL081B, TL082, TL082A, TL082B TL082Y, TL084, TL084A, TL084B, TL084Y JFET-INPUT OPERATIONAL AMPLIFIERS

SLOS081E – FEBRUARY 1977 – REVISED FEBRUARY 1999

- Low Power Consumption
- Wide Common-Mode and Differential Voltage Ranges
- Low Input Bias and Offset Currents
- Output Short-Circuit Protection
- Low Total Harmonic Distortion . . . 0.003% Typ
- High Input Impedance . . . JFET-Input Stage
- Latch-Up-Free Operation
- High Slew Rate . . . 13 V/ μ s Typ
- Common-Mode Input Voltage Range Includes V_{CC+}

description

The TL08x JFET-input operational amplifier family is designed to offer a wider selection than any previously developed operational amplifier family. Each of these JFET-input operational amplifiers incorporates well-matched, high-voltage JFET and bipolar transistors in a monolithic integrated circuit. The devices feature high slew rates, low input bias and offset currents, and low offset voltage temperature coefficient. Offset adjustment and external compensation options are available within the TL08x family.

The C-suffix devices are characterized for operation from 0°C to 70°C. The I-suffix devices are characterized for operation from –40°C to 85°C. The Q-suffix devices are characterized for operation from –40°C to 125°C. The M-suffix devices are characterized for operation over the full military temperature range of –55°C to 125°C.

symbols

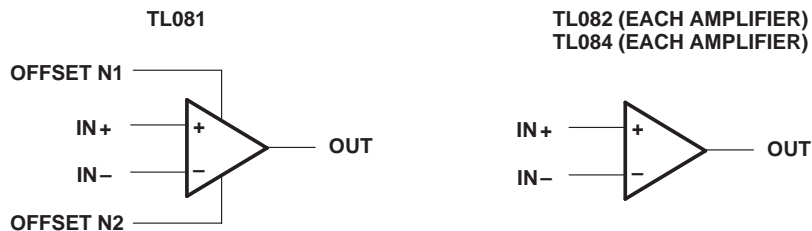

Please be aware that an important notice concerning availability, standard warranty, and use in critical applications of Texas Instruments semiconductor products and disclaimers thereto appears at the end of this data sheet.

PRODUCTION DATA information is current as of publication date. Products conform to specifications per the terms of Texas Instruments standard warranty. Production processing does not necessarily include testing of all parameters.

 **TEXAS
INSTRUMENTS**

POST OFFICE BOX 655303 • DALLAS, TEXAS 75265

Copyright © 1999, Texas Instruments Incorporated
On products compliant to MIL-PRF-38535, all parameters are tested unless otherwise noted. On all other products, production processing does not necessarily include testing of all parameters.

**TL081, TL081A, TL081B, TL082, TL082A, TL082B
TL082Y, TL084, TL084A, TL084B, TL084Y
JFET-INPUT OPERATIONAL AMPLIFIERS**

SLOS081E – FEBRUARY 1977 – REVISED FEBRUARY 1999

**TL081M
U PACKAGE
(TOP VIEW)**

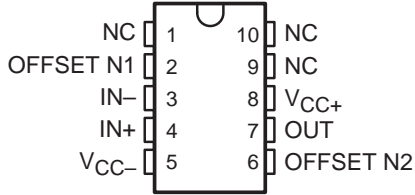

**TL082M
U PACKAGE
(TOP VIEW)**

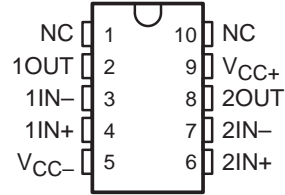

**TL081, TL081A, TL081B
D, JG, P, OR PW PACKAGE
(TOP VIEW)**

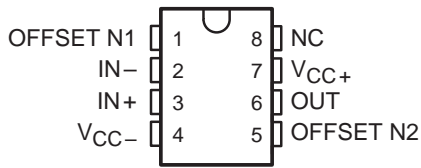

**TL082, TL082A, TL082B
D, JG, P, OR PW PACKAGE
(TOP VIEW)**

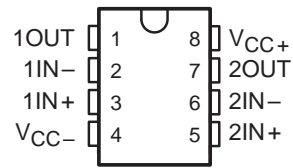

**TL081M . . . FK PACKAGE
(TOP VIEW)**

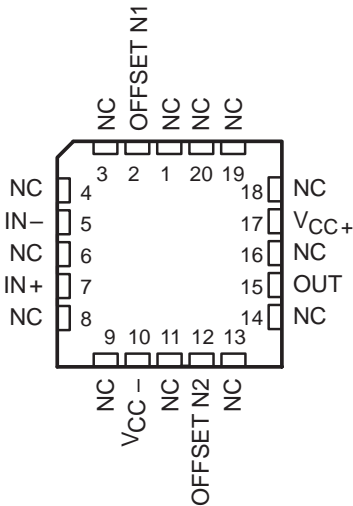

**TL082M . . . FK PACKAGE
(TOP VIEW)**

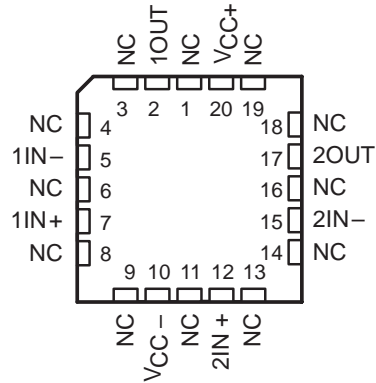

**TL084, TL084A, TL084B
D, J, N, PW, OR W PACKAGE
(TOP VIEW)**

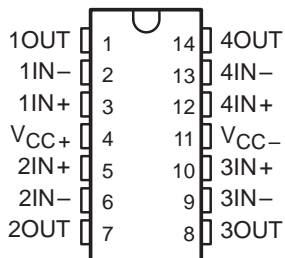

**TL084M . . . FK PACKAGE
(TOP VIEW)**

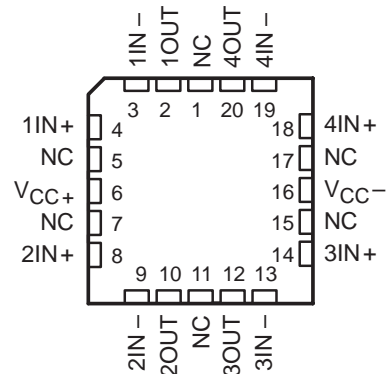

NC – No internal connection