

Two unforgettable experiments of Hungarian scientists

Doing experiments in physics lessons need not cost much. Simple, everyday items and materials can be used for demonstrating physical phenomena. Hungarian physics teachers like József Öveges and Miklós Vermes showed this in the past, along with other Hungarian scientists who followed in their footsteps (for further details of their lives and work see “Hungarian teachers with suitcases full of ‘treasures’” on page 448 of this issue). They were clever at devising experiments from almost nothing. Do

we still need these types of experiments in this day and age? Are these experiments able to divert the attention of pupils who are daily bombarded with information from the media? Experience gained over the years and the results of several detailed surveys seem to bear out our view that a physics education containing experiments made from simple, cheap, everyday objects and a little zeal can indeed motivate young minds. It isn't necessary to constantly splash out on the latest computer-based



Figure 1. Inside of the house.

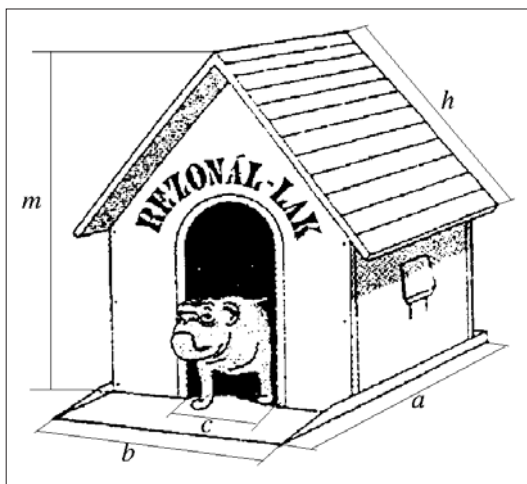

Figure 2. Outside of the house: $a = 20$ cm, $b = 13.5$ cm, $c = 7$ cm, $m = 15$ cm, $h = 9.5$ cm.

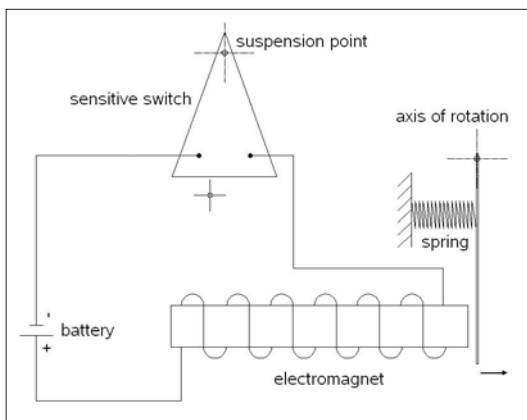

Figure 3. The circuit diagram of the house.

equipment with impressive graphics just to demonstrate one or two physical phenomena. In physics education technology should be used with a little

intelligence.

We now recall two experiments. One is the noted experiment of Professor Öveges that illustrates the resonance of sound waves, while the other, once performed by Vermes, demonstrates how the resistance of conductors depends on various parameters such as their dimensions. The detailed explanation will hopefully urge teachers, students and laypersons alike to construct these delightful toys for themselves. Through curiosity and careful observation we can learn much about the natural wonders that we mostly take for granted.

Heki and his house

This is a house made of paper with a simple idea behind it (figures 1 and 2). When connected up, a circuit with a battery (4.5 V) and an electromagnet ($N = 1000$) attracts a laminated spring. Heki, the dog, sits close to the laminated spring. The back of the dog touches the spring, which is attracted by the electromagnet. The circuit is closed by a little contact and two small metal plates ($d = 0.8$ cm) attached to one of the paper walls as shown in figure 3. We have tried contacts made of different metals in various sizes. Our experience shows that the lighter the contact, the more sensitive to wave sounds is the circuit. The most suitable contact is a triangular one whose sides are about 1–2 cm long. This metal strip connects the two small metal plates, which are connected to the electromagnet on one side and to the battery on the other side.

When we shout something near the house the metal strip swings out for a moment as an effect of the sound waves (resonance of sound waves inside the house). As a consequence the two metal plates are briefly separated, causing the circuit to break. The electromagnet no longer attracts the laminated spring, which moves away from the electromagnet and pushes the dog out of the house (as seen in figure 4).

To make it work as before, just push the spring onto the electromagnet. The metal strip on the wall closes the circuit until we shout the dog's name, or perhaps 'Cats'. This will make Heki, who is ever alert, come out from his house.

In another version of the house a small contact attached to the 'ceiling' (rather than a metal strip on the wall) closes the circuit. Sound waves make the contact move slightly, causing the circuit to

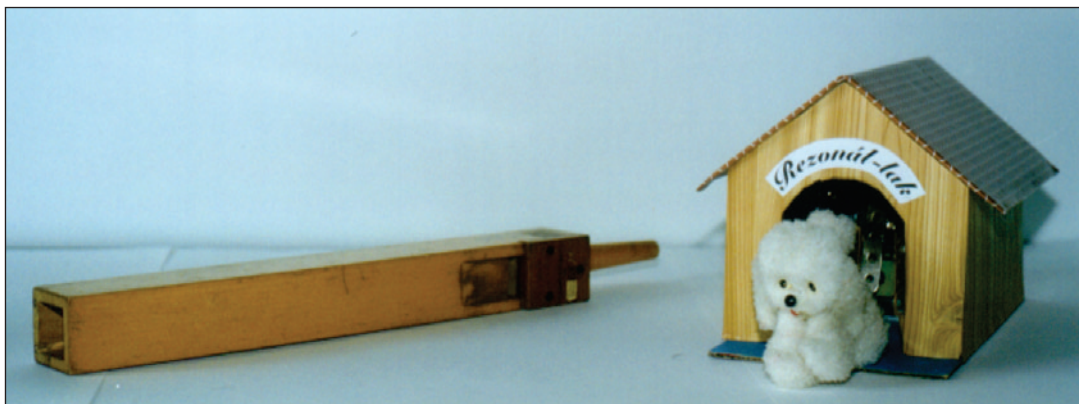

Figure 4. *Heki and his house.*

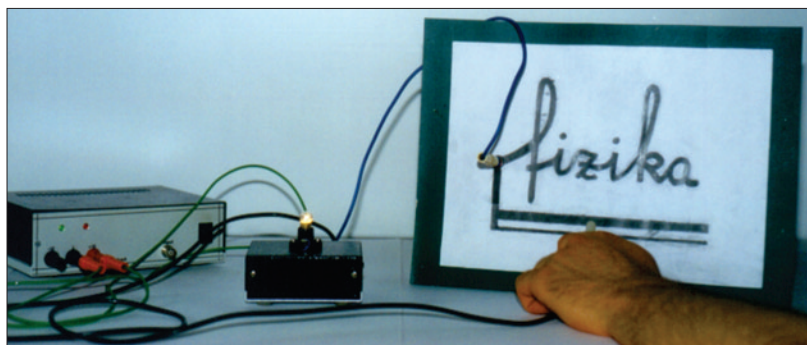

Figure 5. *The graphite message.*

break, and once again the spring makes the faithful Heki peek out from his house.

Graphite messages

Using a simple DC amplifier and a message drawn by a graphite pencil a set-up can be constructed to demonstrate how resistance depends on both the length and cross section of the conductor. If the inscription is 'physics', say, we can even demonstrate how physics conducts.

The inscription, which will be part of a circuit, is written on an A4 sheet of paper with a graphite pencil without any discontinuity. This requires some time to do as we need quite a thick layer of graphite to significantly reduce the resistance. In addition to the inscription we can draw two lines, one narrow and one wider, to show that the resistance depends not just on the length but on the diameter of the conductors as well. The resistance between the two ends of the graphite circuit is about $2\text{ M}\Omega$.

First connect the conductor with a 5 V supply,

then measure the electric current flowing through the amplifier with a bulb. When a photograph is taken of the set-up (figure 5) it reveals that a change in the brightness of the light bulb provides a measure of the change in resistance of the graphite layer.

Professor Öveges and Miklós Vermes differed

from each other in many respects, but they had one or two things in common as well. Both had ancient suitcases full of 'treasures', seeing possibilities that the majority of us simply overlook. With these treasures they practised magic in physics lessons for elementary and secondary pupils, and for the layperson on television. We should cherish the memory of these wonderful teachers by showing a few of their treasures to young people today.

Further reading

Papp K, Nagy A and Bohus J 2000 *Két elfelejtett kísérlet* (OKSZI Módszertani lapok, Fizika) vol. 4
Siddons C 1988 *Experiments in Physics* (Oxford: Blackwell)

Katalin Papp, Anett Nagy, Miklós Molnár and János Bohus

Department of Experimental Physics, University of Szeged, Hungary
pkat@physx.u-szeged.hu